

ShelleyAutomation



Machine Vision



Collaborative Robots



Pneumatics



Safety, Sensing & Wireless



Controls & HMI

What Customers Say About Us

"They provide us with great products, good customer service and on-site support as needed. Shelley understands the high standards that our company requires and are most effective in meeting our technical and commercial expectations."

*Dave Evans, Automation Manager
Massiv Automated Systems*

"Shelley Automation has been a key partner to Innovative Automation throughout our journey, and will continue to be a key partner in helping us to ensure that OUR customers receive the best solutions for their automation needs."

*Steve Loftus, President
Innovative Automation Inc.*

"We have worked on several projects that involve vision systems and other sensors. Shelley is my first choice to go to because they listen first, then provide us with their recommendations. Excellent products, amazing customer service and outstanding technical support."

*Andy Alubaidy, Professor
Sheridan College*

"We appreciate how well Shelley Automation responds to our needs; they have done excellent work delivering engineered inspection solutions for our projects. Great people and great support!"

*David Langen, Controls Manager
AFA Systems Ltd.*

Machine Vision

- In-sight smart cameras
- Cameras powered by AI
- 2D and 3D laser profiling
- 3D area scanner
- 4D vision (x, y, z + AI)
- Vision sensors
- Thermal Imaging

AI Vision Solutions

- Leveraging neural networks for vision guidance.
- AI and machine learning power 4D Vision to create new levels of robotic performance and intelligence.
- Intuitive software for easy implementation of AI/deep learning-based computer vision models.

Barcode Reading

- Fixed mount
- Handheld
- Barcode verifiers
- Mobile solutions
- ESD-safe

Vision Lighting

- Back light
- Linear bar light
- Diffuse dome ring lights
- Diffuse on axis
- Flat dome
- Low angle dark field
- Ring light
- Over 5000 models available



Sensing & Measurement

- Photoelectric
- LASER distance measurement
- Ultrasonic
- Fiber optic sensors & amplifiers
- Measuring arrays
- Radar sensors
- Temperature & vibration
- Pick-to-light
- Precision laser triangulation
- LASER time of flight
- Capacitive
- Inductive

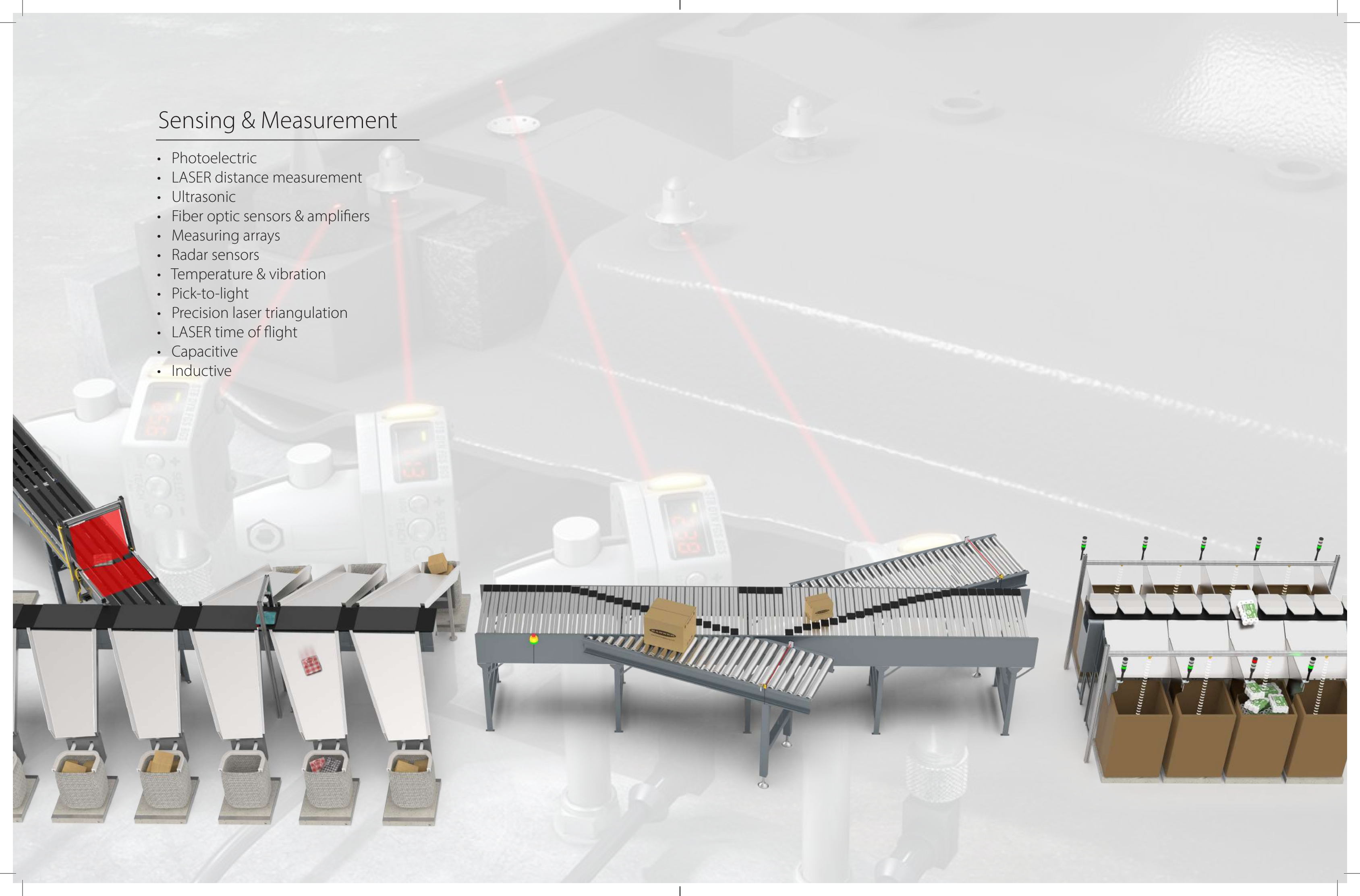

Mechatronics

- **Linear & Rotary Positioners**
 - Ball screw & lead screw tables
 - Belt driven linear actuators
 - Linear motor positioners
 - Miniature linear stages
 - Electric cylinders
 - Gantry robots
 - Cartesian robots
 - Linear guides & ball screws
 - Manual slides & stages

Motion & Machine Control

- **Motors**
 - Rotary servo motors
 - Stepper motors
 - Linear/rotary direct drive motors
 - Integrated smart servo motors
 - Kit motors
 - Explosion proof motors
 - Wash down servo motors
- **Drives & Controllers**
 - Multi-axis motion & machine controllers
 - PC based machine controller for motion, logic, kinematics, safety, security and more
 - Supports next generation IEC61131-3 programming environments
 - Servo drives
 - Stepper drives

Encoders

- Absolute
- Incremental
- Linear
- Programmable

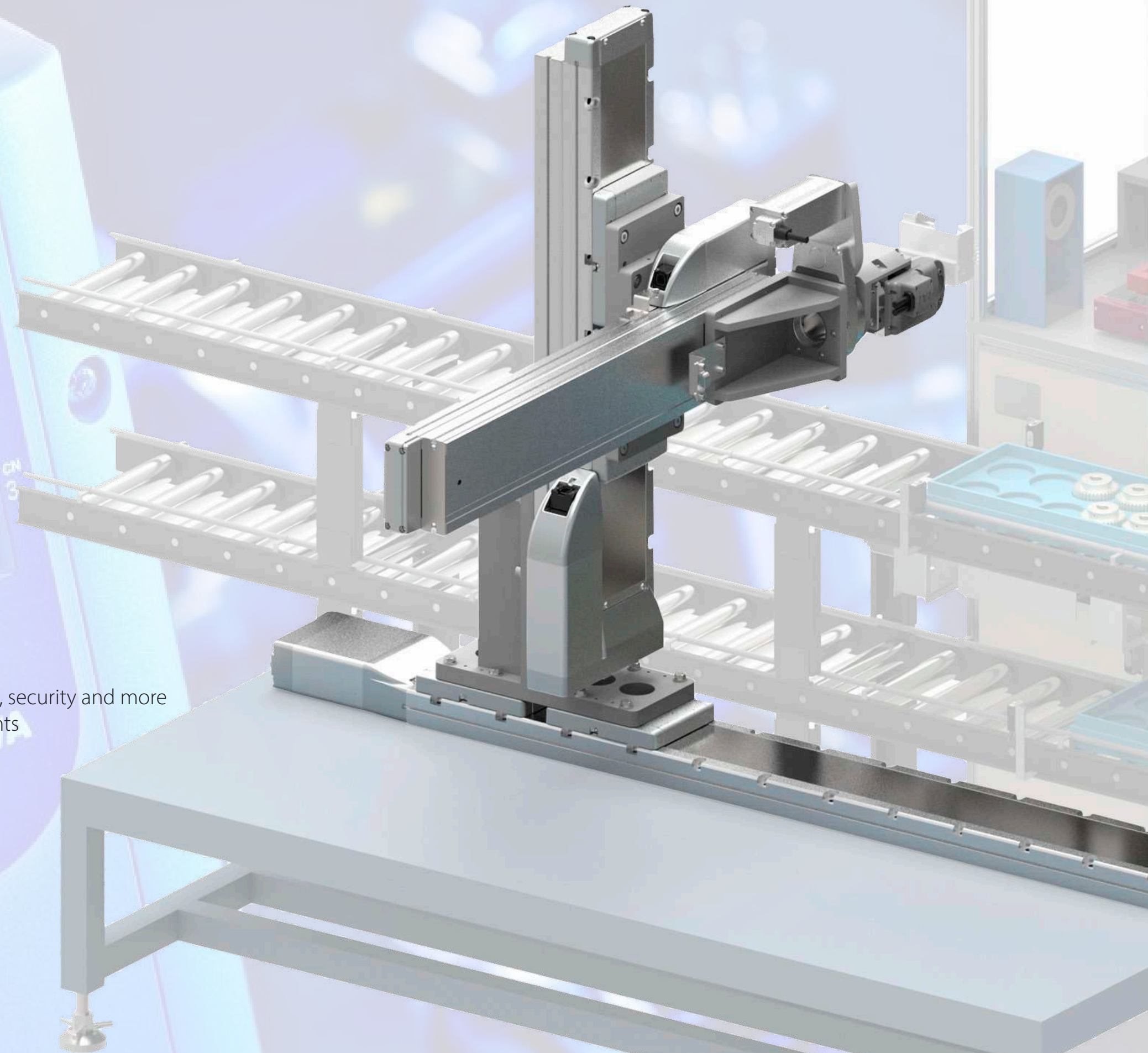



Pneumatics

- Actuators and large bore tubing up to 41 inches
- Valves & pre-assembled manifolds
- Airline equipment & pre-assembled FRLs
- Connectors
- Electrical products
- Flexible positioning unit
- Vacuum cups, ejectors & pumps
- Dryers
- Sensors, switches & flow meters
- Fluid process
- Static control
- Chillers
- Speciality equipment

Safety Solutions

- Light curtains & LASER area scanners
- Safety fence system
- Interlock switches
- E-stops
- Programmable safety controllers
- Safety relays
- Force guided relays
- Two-hand controls

Industrial Networking & Smart IO

- Radios
- Controllers
- Sensors & nodes for condition monitoring
- Push button & switches
- Machine & motor vibration monitoring
- Tank level monitoring
- Temperature & humidity monitoring
- Predictive maintenance

Visualization & Indication Solutions

- LED indicators & lighting
- Tower lights
- Touch buttons
- Pick-to-lights

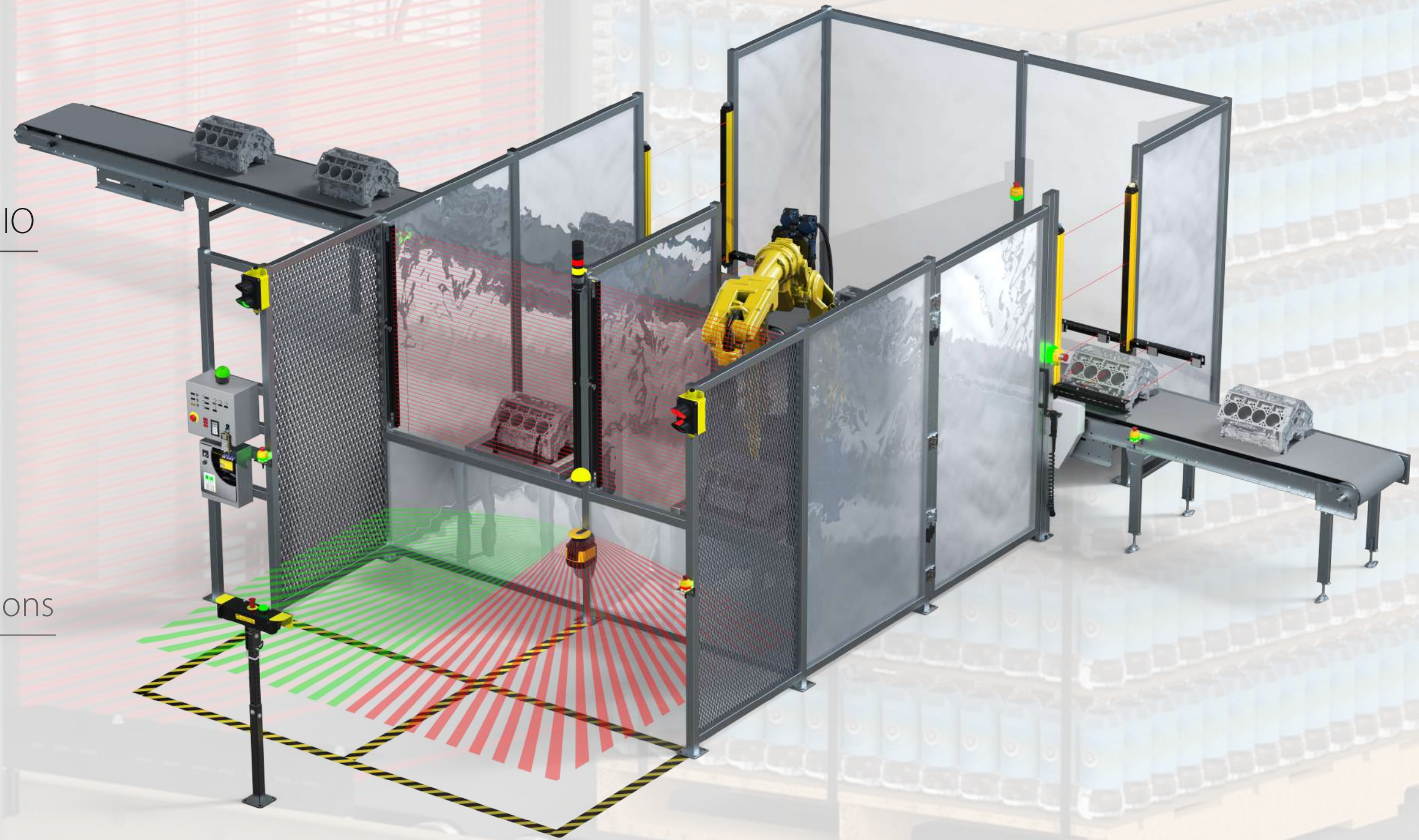

Direct Part Marking, ID & Traceability Solutions

- Industrial Galvo & Table LASERS
 - Fiber
 - Hybrid
 - Green
 - CO2
- Dot Peen
 - Hand held
 - Bench top
- Scribe
- Engraving Stations & CNC Tables

LASER Work Stations

- LW2-Touch fully automated class 1 LASER enclosure
- LW3-Touch double sized fully automated class 1 LASER enclosure
- Mini in-line class 1 LASER enclosure

Barcode Reading & Verification

- Fixed mount
- Hand held
- Barcode verifiers
- OCR verification and read

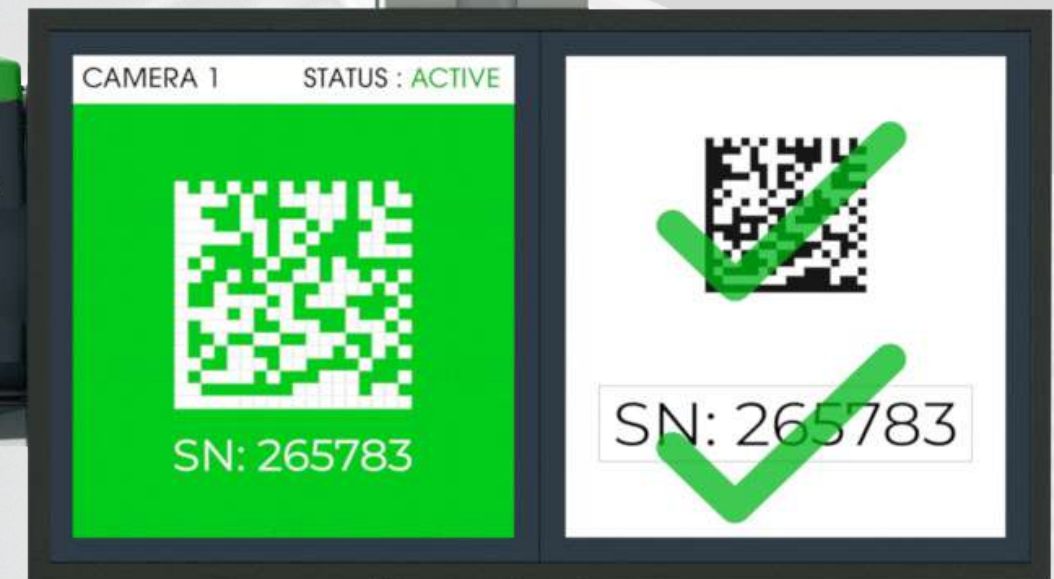
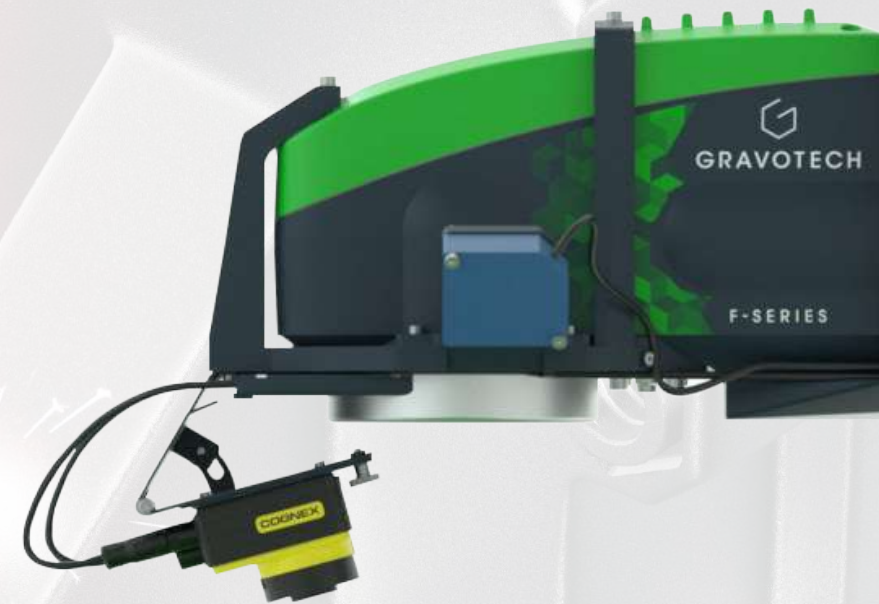

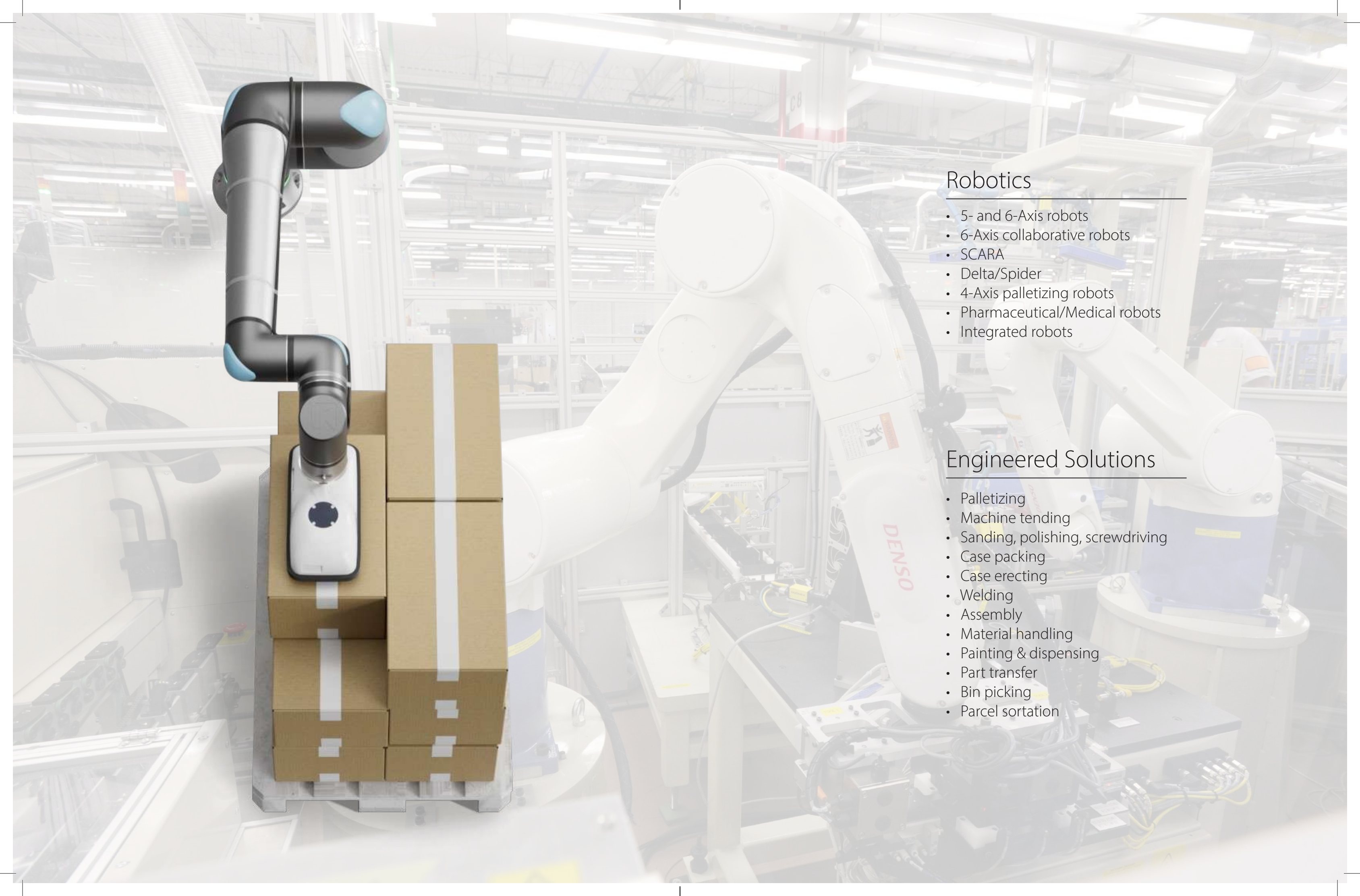

Robotics

- 5- and 6-Axis robots
- 6-Axis collaborative robots
- SCARA
- Delta/Spider
- 4-Axis palletizing robots
- Pharmaceutical/Medical robots
- Integrated robots

Engineered Solutions

- Palletizing
- Machine tending
- Sanding, polishing, screwdriving
- Case packing
- Case erecting
- Welding
- Assembly
- Material handling
- Painting & dispensing
- Part transfer
- Bin picking
- Parcel sortation

Autonomous Mobile Robot Features

- Optimize productivity and internal workflows.
- Automate repetitive and injury-prone tasks.
- Safe, adaptable, cost-effective and easy to deploy.

Top Module Solutions

- Conveyors
- Lifts
- Collaborative robot arm
- Frames & shelves
- Anchoring devices
- Stations
- Communication
- Disinfection & body temperature detection
- Customizable design & fabrication

Industries

- Automotive
- Electronics
- Fast moving consumer goods
- Logistics & 3PL
- Life science
- Healthcare



Conveyors

- Accumulation
- Custom conveyor systems
- Product handling
- Inspection & testing
- Elevations & line egress
- Indexing & positioning
- Depositing & rejects
- Product flow & control
- Merge, diverting and sorting

Engineered Solutions

- Flippers & rotators
- Chicaning
- Bottom-less
- Diverters, pushers & gates
- Chutes & hoppers
- Retracting tails
- Lift gate
- Settling
- Vacuum belt
- Pop-up transfers
- Metal detection
- Backlit conveyors
- Magnetic conveyors
- Belt-over-belt conveyors



Industrial Internet Of Things (IIoT)

- Operator Panels & Touchscreens
 - Dedicated HMI
 - Industrial PCs
 - Large LED displays
 - Visual management systems
- Managed & unmanaged Ethernet switches
- Industrial PoE
- Media converters

Power Supplies

- 1-phase & 3-phase
- IP67 field power supplies
- DC/CD converters
- IO-Link
- Power & Ethernet
- DC-UPS & buffer modules
- Redundancy modules
- Protection modules



Automation Frames

- Structural Frames
- Mounting & tooling
- Robot cells
- Cobot pedestals & carts
- Lift column
- Benches & trolleys
- Drawer system for machine tending
- Cobot assembly kits
- Standard & custom solutions
- Workstations
- Safety Enclosures

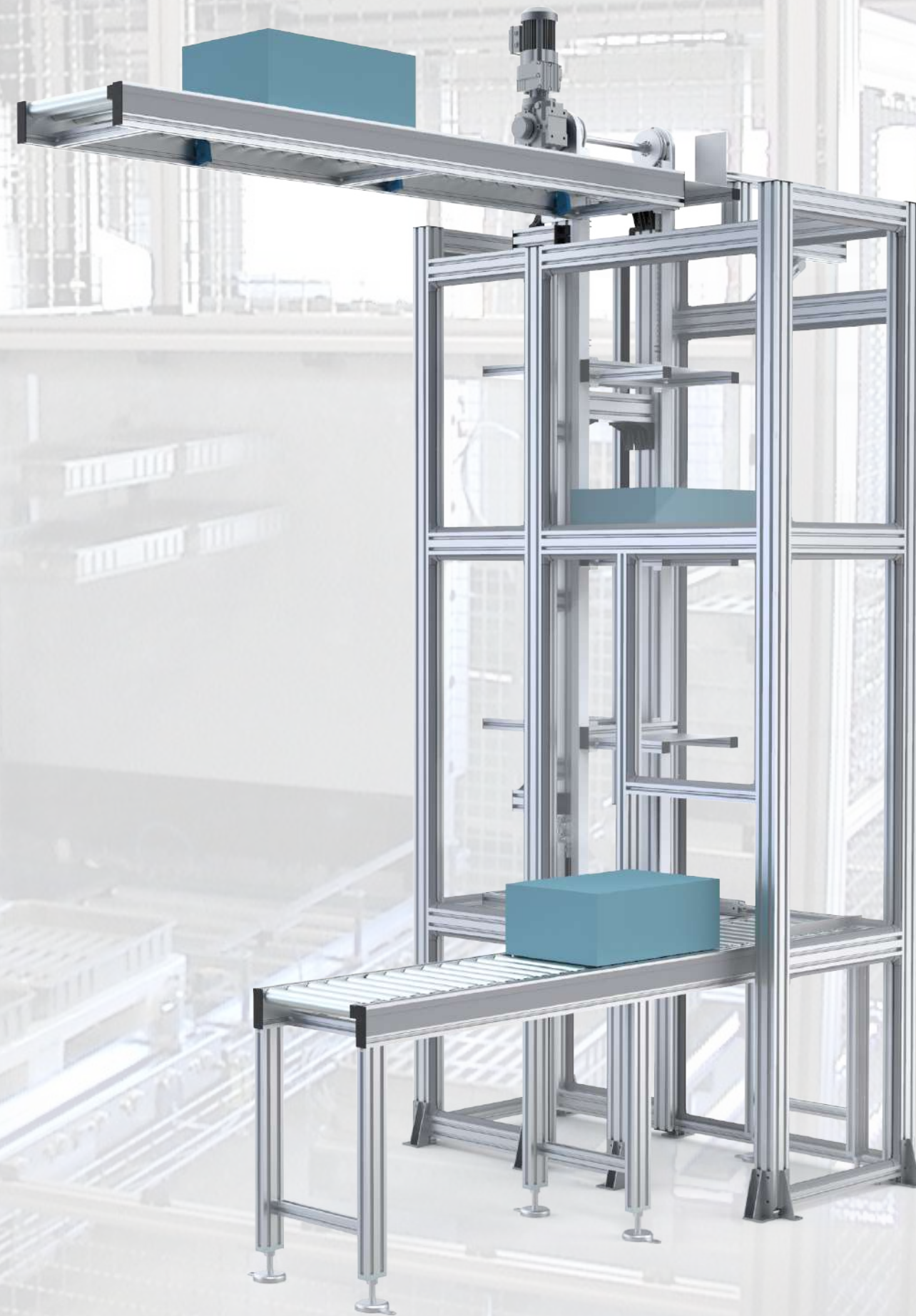

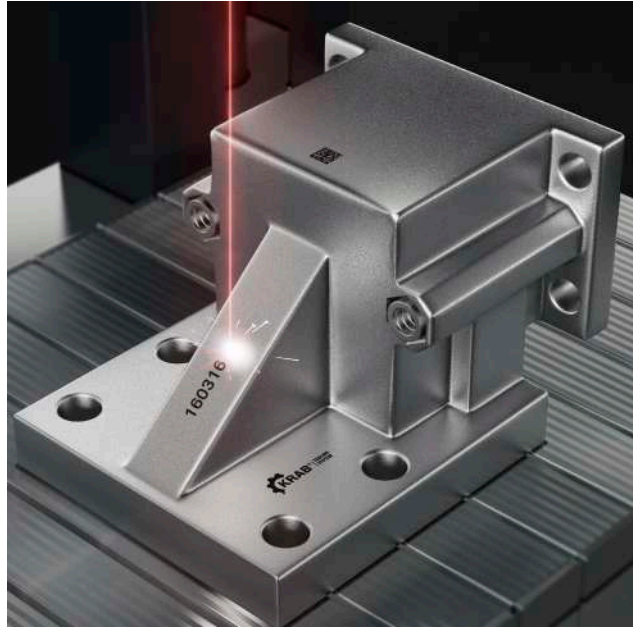

Value-Added Services

- Start-up assistance
- Free Training, Workshops and Seminars
- Lab Test Center
- Robotic Feasibilities
- Machine Vision Feasibilities
- Factory Certified Repair Center
- IPS Design Center
- Installations
- Programming
- Pneumatic Manifold & FRL Assembly

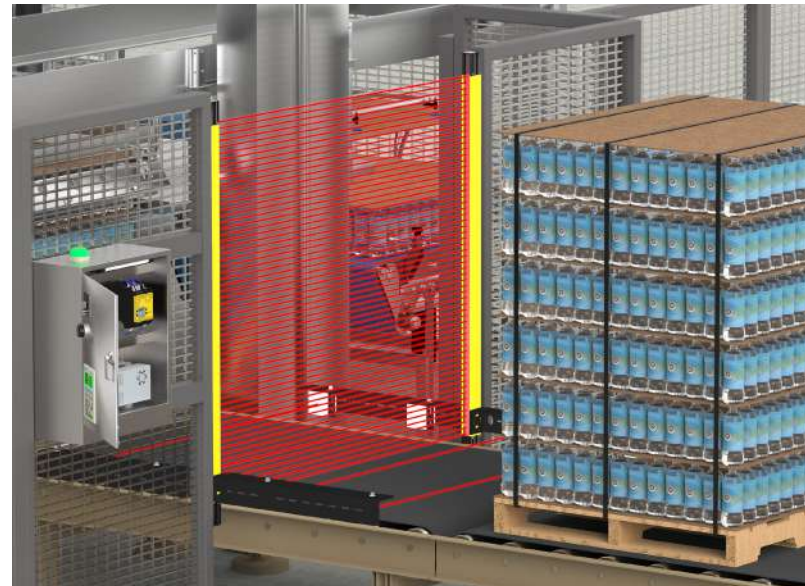

12 REASONS TO PARTNER WITH US

1. Top tier distributor for multiple product lines
2. 50+ technology brands
3. 2300+ returning customers
4. More than 4 million dollars worth of stock
5. All outside sales reps have a technical background
6. 31 outside sales reps, 12 tech support reps
7. Multiple offices and labs across Canada
8. Leader in robotics and machine vision systems
9. Servicing Industries for 60 years
10. 100% Canadian company
11. Value-added capabilities
12. Customer happiness is our top priority

Toronto Office

41 Coldwater Road
Toronto, Ontario
M3B 1Y8
Tel: (416) 447-6471

Markham Office

4-80 Citizen Court
Markham, Ontario
L6G 1A7
Tel: (416) 447-6471

Cambridge Office

5-320B Pinebush Road
Cambridge, Ontario
N1T 1Z6
Tel: (519) 650-3890

Windsor Office

140-55 Edinborough Street
Windsor, Ontario
N8X 3C3
Tel: (519) 251-9966

Delta Office

112-7350 72nd Street
Vancouver, British Columbia
V4G 1H9
Tel: (604) 952-4020

Calgary Office

110-3442 118 Avenue S.E.
Calgary, Alberta
T2Z 3X1
Tel: (403) 254-8900

Edmonton Office

17427-105 Avenue
Edmonton, Alberta
T5S 2G8
Tel: (780) 437-5910

 info@shelley.com www.shelley.com Shelley Automation Shelley Automation

Mechatronics



Industrial Robots



Conveyors



LASER, Dot Peen & Scribe



ID Reading